

Tyre Couplings

LOVEJOY INDIA® RLT

Standard Series with Straight Bores and Keyways (B) or Taper Bushes (F/H), with or without Spacer

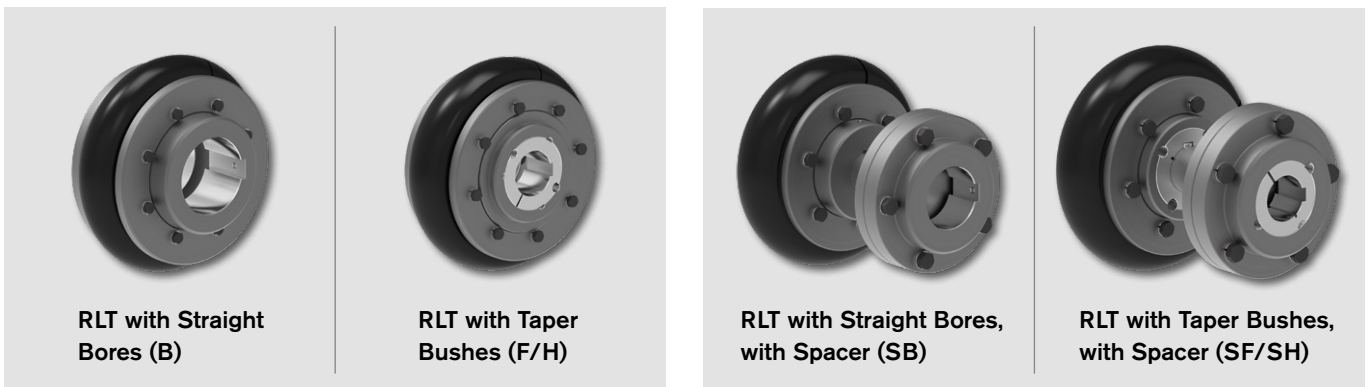

Speed 1/min	Power Rating (kW)														
	RLT Size														
	40	50	60	70	80	90	100	110	120	140	160	180	200	220	250
100	0.25	0.69	1.33	2.62	3.93	5.24	7.07	9.16	13.9	24.3	39.5	65.7	97.6	121	154
750	1.87	5.17	9.97	19.65	29.47	39.30	53.02	68.70	104.25	182.25	296.25	492.75	732	907.5	1155
1000	2.50	6.90	13.30	26.20	39.30	52.40	70.70	91.60	139.0	243.0	395.0	657.0	976	1215	1537
1500	3.75	10.35	19.95	39.30	58.95	78.60	106.05	137.40	208.50	364.50	592.50 *	986.5 *	-	-	-
1800	4.50	12.42	23.94	47.16	70.74	94.32	127.26	164.88	250.20	437.40 *	-	-	-	-	-
3000	7.50	20.70	39.90	78.60	117.90 *	157.20 *	-	-	-	-	-	-	-	-	-
3600	9.00	24.84	47.98	94.32	-	-	-	-	-	-	-	-	-	-	-

- All these power ratings are calculated at constant torque.
- For speeds below 100 1/min and intermediate speeds use normal torque ratings.
- * Dynamic balancing preferred at these speeds.

Poles	2	4	6	8
1/min	3000	1500	1000	750

		Technical Data – Flexible Tyres														
Size		40	50	60	70	80	90	100	110	120	140	160	180	200	220	250
Max. Speed	1/min	4500	4500	4000	3600	3100	3000	2600	2300	2050	1800	1600	1500	1300	1100	1000
Torsional Stiffness	Nm/Deg.	5	13	26	41	63	91	126	178	296	470	778	1371	1959	2760	3562
Parallel Misalignment	mm	1.1	1.3	1.6	1.9	2.1	2.4	2.6	2.9	3.2	3.7	4.2	4.8	5.3	5.8	6.6
End Float	mm	1.3	1.7	2.0	2.3	2.6	3.0	3.3	3.7	4.0	4.6	5.3	6.0	6.6	7.3	8.2
Normal Torque	Nm	24	66	127	250	375	500	675	875	1330	2325	3730	6270	9325	11600	14675
Max. Torque	Nm	64	160	318	487	759	1096	1517	2137	3547	5642	9339	16455	23508	33125	42740

- The flexible capabilities of the Tyreflex Coupling help to accommodate angular, parallel and axial misalignments.
- Parallel Misalignment upto 6 mm. Angular Misalignment up to 4°. End Float up to 8 mm. Suitable in ambient temp. up to 70 °C.

To continue see next page

Tyre Couplings LOVEJOY INDIA® RLT

RLT B: Type with Straight Bores

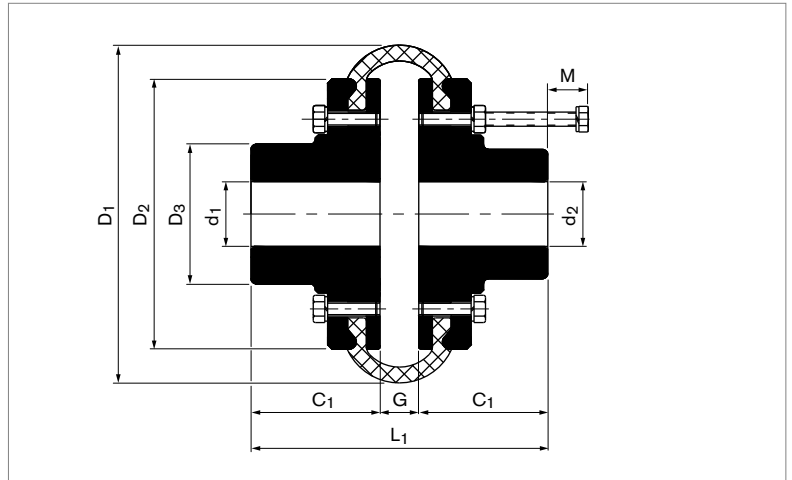

Dimensions of RLT Bore B											
RLT Size	n_{max} 1/min	d_1/d_2		L_1	C_1	D_1	D_2	D_3	G	M	G_w
		Min. mm	Max. mm								
40	4500	10	32	68	22	104	82	-	24	40	1.9
50	4500	10	38	93	32	133	100	79	29	50	3.5
60	4000	15	45	111	38	165	125	73	35	31	5
70	3600	19	50	106	45	197	144	82	16	21	8.4
80	3100	25	63	124	51	210	167	96	22	26	11.5
90	3000	30	75	138	57	235	188	110	24	22	16
100	2600	32	80	144	60	254	216	125	24	26	22.7
110	2300	32	90	152	65	279	233	140	22	22	28.3
120	2050	38	100	177	76	314	264	152	25	21	40.1
140	1800	58	125	201	89	359	311	195	23	31	60.6
160	1600	65	140	212	102	395	345	216	8	40	86.4
180	1500	70	150	254	116	470	398	220	22	41	133.3
200	1300	70	150	258	114	508	429	220	30	52	144.6
220	1100	75	160	281	127	562	470	240	27	44	181.63
250	1000	85	190	294	132	628	532	275	30	80	281.1

To continue see next page

Tyre Couplings LOVEJOY INDIA® RLT

RLT F/H: Type with Taper Bushes

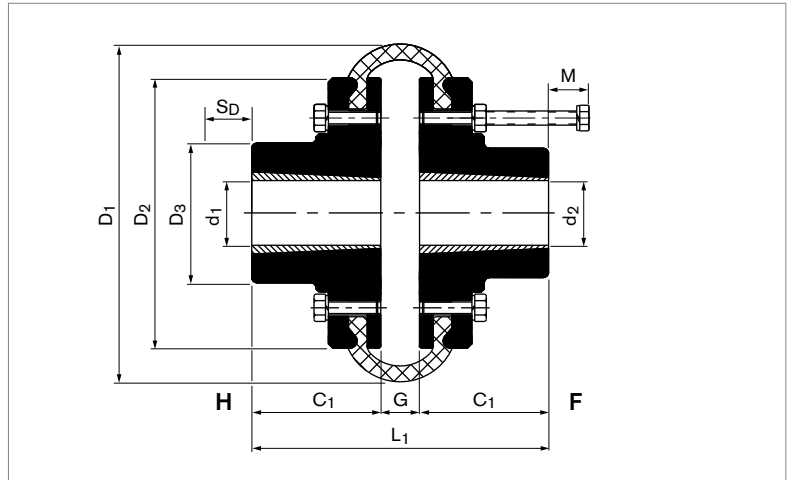

Dimensions of RLT Bore F/H																			
RLT Size	n _{max}	Bush Size		Max. Bore Diameter d ₁ /d ₂		L ₁		C ₁		S _D		D ₁	D ₂	D ₃	G	M		Gw	
		F	H	F	H	F	H	F	H	F	H	F/H	F/H	F/H	F/H	F	H	F	H
	1/min	mm		mm		mm		mm		mm		mm	mm	mm	mm	mm		kg	
40	4500	1008		22		68		22		37		104	82	-	24	40		1.7	
50	4500	1210		32		79		25		46		133	100	79	29	50		2.7	
60	4000	1610		35		85		25		46			125	103	35	45		3.6	
70	3600	2012	1610	45	35	80	66	32	25	38	46	197	144	82	16	41	34	6.35	6.2
80	3100	2517	2012	60	45	112	86	45	32	42	56	210	167	98	22	45	32	8.53	8.5
90	3000	2517		60		114		45		62		235	188	110	24	34		12	
100	2600	3020	2517	75	60	126	114	51	45	48	62	254	216	125	24	41	35	18.2	18.1
110	2300	3020		75		124		51		73		279	233	140	22	36		21.1	
120	2050	3525	3020	90	75	155	127	65	51	55	73	314	264	152	25	46	32	30.33	30.3
140	1800	3525		90		153		65		75		359	311	195	23	55		42.6	
160	1600	4030		100		162		77		86		395	345	216	8	65		72.6	
180	1500	4535		110		200		89		97		470	398	220	22	68		123	
200	1300	4535		110		208		89		97		508	429	220	30	77		158.3	
220	1100	5040		125		231		102		113			470	240	27	69		195.1	

To continue see next page

Tyre Couplings LOVEJOY INDIA® RLT

RLT SB: Type with Straight Bores, with Spacer

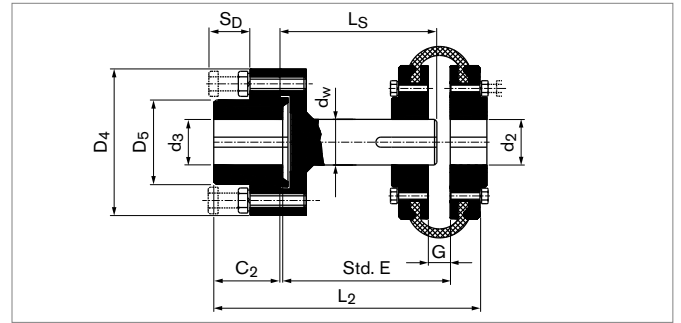

Dimensions of RLT SB															
Spacer Size	Std. E	d ₃		D ₄	D ₅	L ₂	C ₂	S _D	L _S	d _w	RLT Size	d ₂		G	
		Min.	Max.									Min.	Max.		
	mm	mm	mm	mm	mm	mm	mm	mm	mm	mm		mm	mm	mm	
12	80	10	42	118	83	127	25	22	57	25	40	10	32	24	
	100														
16	100	18	48	127	80	160	38	24	94	32	40	10	32	24	
	140					200			134		40				
	100					170			94		10				38
	140					210			134		10				38
	100					176			94		15				45
	140					216			134		15				45
	140														
25	100	38	80	178	127	190	45	27	94	48	70	19	50	16	
	140					230			134		19				50
	180					270			174		19				50
	100					196			94		25				63
	140					236			134		25				63
	180					276			174		25				63
	140					242			134		30				75
	180					282			174		30				75
30	140	40	90	216	146	276	76	33	134	60	100	32	80	24	
	180					316			174		32				80
	140					281			134		32				90
	180					321			174		32				90
	180														
35	140	66	110	248	178	305	89	33	134	80	120	38	100	25	
	180					345			174		38				100
	180					358			174		58				125

To continue see next page

Tyre Couplings LOVEJOY INDIA® RLT

RLT SF/SH: Type with Taper Bushes, with Spacer

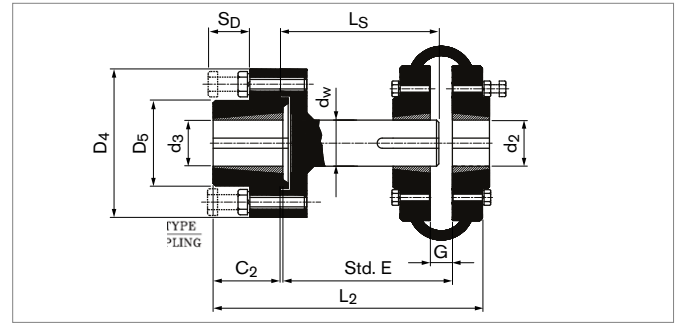

Dimensions of RLT SF/SH														
Spacer Size	Std. E	Taper Bush		D ₄	D ₅	L ₂	C ₂	S _D	L _S	d _w	RLT Size	Taper Bush		G
		Size	Max. Bore Diameter d ₃									Size	Max. Bore Diameter d ₂	
		mm	mm	mm	mm	mm	mm	mm	mm	mm		mm	mm	mm
12	80	1210	32	118	83	127	25	22	57	25	40	1008	22	24
	100													
16	100	1615	42	127	80	160	38	24	94	32	40	1008	22	24
	140													
	100													
	140													
	100													
	140													
25	100	2517	60	178	127	180	45	27	94	48	70F	2012	45	16
	140													
	180													
	100													
	140													
	180													
	140													
	180													
30	140	3030	75	216	146	270	76	33	134	60	100F	3020	75	24
	180													
	140													
	180													
35	140	3535	90	248	178	297	89	33	134	80	120F	3525	90	25
	180													
	140													
	180													
	140													

Std. Distance Between Shaft Ends (Std. E)																				
RLT Size	Spacer 12		Spacer 16				Spacer 25				Spacer 30				Spacer 35					
	80		100		140		100		140		180		140		180		140		180	
	Min	Max	Min	Max	Min	Max	Min	Max	Min	Max	Min	Max	Min	Max	Min	Max	Min	Max	Min	Max
40	80	100	100	113	140	153	-	-	-	-	-	-	-	-	-	-	-	-	-	-
50	-	-	100	116	140	153	-	-	-	-	-	-	-	-	-	-	-	-	-	-
60	-	-	100	124	140	164	-	-	-	-	-	-	-	-	-	-	-	-	-	-
70F	-	-	-	-	-	-	100	107	140	147	180	187	-	-	-	-	-	-	-	-
80F	-	-	-	-	-	-	100	112	140	152	180	192	-	-	-	-	-	-	-	-
90	-	-	-	-	-	-	-	-	140	155	180	195	-	-	-	-	-	-	-	-
100F	-	-	-	-	-	-	-	-	-	-	-	-	140	151	180	191	-	-	-	-
110	-	-	-	-	-	-	-	-	-	-	-	-	140	151	180	192	-	-	-	-
120F	-	-	-	-	-	-	-	-	-	-	-	-	-	-	-	-	140	156	180	196
140	-	-	-	-	-	-	-	-	-	-	-	-	-	-	-	-	140	153	180	193

To continue see next page

Tyre Couplings LOVEJOY INDIA® RLT

Explanations

n_{max} = Max. Rotational Speed	Std. E = Std. Distance Between Shaft Ends	M = Amount by which the Clamping Screw must be pulled out to loosen Tyres
d₁/d₂/d₃ = Bore Diameter Hubs & Bushes	L₁/L₂ = Total Length	S_D = Disassembly Space
D₁ = Max. Outer Diameter	L_S = Intermediate Part Length	G_w = Approx. Weight
D₂/D₄ = Max. Outer Diameter Hubs	d_w = Intermediate Shaft Diameter	
D₃/D₅ = Outer Diameter Hubs	G = Width of Gap Between Left and Right Component	
C₁/C₂ = Guided Length in Bore		

Technical Information

- All dimensions are in millimeters, unless otherwise specified. Decimal points are used as decimal separators.
- For size 40 of RLT Bore B, a flange must be used for mounting the spacer shaft.
- With RLT Bore B, up to size 60 the Tyre is clamped from the inside. From size 70 and above, it is clamped from the outside.
- With RLT Bore F/H, up to size 60 the Tyre is clamped from the inside. From size 70 and above, it is clamped from the outside.
- Shaft ends, although normally located G apart can project beyond flanges.
- Weight & Moment of inertia specified for solid bores.
- For detailed information about taper bush bore, please contact RINGFEDER POWER TRANSMISSION.
- Non-Std. spacers are available on request.
- Taper Lock Bushes can be mounted from the inside "F" or from the outside "H". Selection is made in the order.
- RLT Tyre Couplings are also available with mixed hub variations. Selection is made via the type in the order.
- For other types of shaft-hub-connections, please contact RINGFEDER POWER TRANSMISSION.

Ordering example RLT

Series	Type	Size	Tyre-Material	Bore Diameter d ₁	Bore Diameter d ₂
RLT	FIF	100	FRAS	60	70

Additional Ordering Example in case of RLT with Spacer

Series	Type	Spacer Size	Distance between Shaft Ends 'E'	Bore Diameter d ₃
RLT	SF	30	140	70

Ordering Information

- Type Definition: Left Hub - Clamping - Right Hub
- Hub Definition: B = Straight Bore and Keyway, F = Taper Bush mounted from the inside, H = Taper Bush mounted from the outside
- Clamping Definition: I = Tyre clamped from the inside, O = Tyre clamped from the outside
- Tyre Materials: STDR = Natural Rubber (standard), NEUR = Natural Rubber (without labeling), FRAS = Fire Resistant Anti Static
- Without further specifications, we deliver hubs of type B as standard: Bore tolerance H7; Keyway acc. to DIN 6885-1; Keyway width tolerance JS9; Set screw per hub. For bores complying with AGMA or other specifications, please contact RINGFEDER POWER TRANSMISSION.

Disclaimer of liability

All technical details and notes are non-binding and cannot be used as a basis for legal claims. The user is obligated to determine whether the represented products meet his requirements. We reserve the right to carry out modifications at any time in the interests of technical progress.