

TAPER GRID COUPLINGS TYPE RGTV

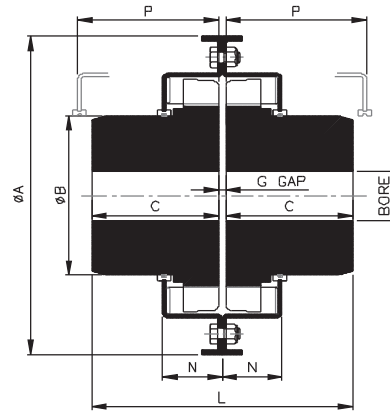

TYPE RGTV

- Vertical split cover: Ideal for higher running speeds and general purpose applications.
- Lubrication fittings: One or more lube holes in each half cover makes for easier lubrication. Fill through one and remove other plug for venting.
- Seals: Durable synthetic material prevents loss of lubricant & entrance of water, dust or other foreign materials.
- Hubs: Made of steel for maximum strength.
- Taper Grid: Made of high strength steel, quenched and tempered to spring hardness.

TECHNICAL DATA

Coupling Size	KW at 100 RPM	Basic Torque (Nm)	Max. Speed (rpm)	PB	Bore Dia (mm)		Dimensions (mm)						G Gap (mm)	Lube weight (kg)	Coupling Wt. WO Bore (kg)
					Min.	Max.	ØA	ØB	C	L	N	P			
1020	0.54	52	6000	16	18.0	30.0	111.0	39.7	47.5	98.0	24.0	47.5	3.0	0.030	2.0
1030	1.56	149	6000	16	18.0	36.0	121.0	49.2	47.5	98.0	25.0	47.5	3.0	0.030	2.6
1040	2.61	249	6000	16	18.0	44.0	128.5	57.1	51.0	104.5	25.5	51.0	3.0	0.050	3.4
1050	4.56	435	6000	16	18.0	51.0	147.5	66.7	60.5	123.5	31.0	60.5	3.0	0.050	5.4
1060	7.16	684	6000	16	18.0	57.0	162.0	76.2	63.5	130.0	32.0	63.5	3.0	0.090	7.3
1070	10.41	994	5500	16	18.0	68.0	173.0	87.3	76.0	155.5	33.5	76.0	3.0	0.110	10.4
1080	21.47	2050	4750	25	27.0	82.0	200.0	104.8	89.0	181.0	44.0	89.0	3.0	0.170	17.7
1090	39.06	3730	4000	25	27.0	95.0	232.0	123.8	98.5	200.0	47.5	98.5	3.0	0.250	25.4
1100	65.76	6280	3250	38	40.0	110.0	267.0	142.0	120.5	245.5	60.0	120.5	4.5	0.430	42.2
1110	97.60	9320	3000	38	40.0	120.0	286.0	160.3	127.0	258.5	64.0	127.0	4.5	0.510	54.4
1120	143.47	13700	2700	50	52.0	140.0	319.0	179.4	149.0	304.5	73.5	149.0	6.0	0.730	81.6
1130	208.39	19900	2400	50	52.0	170.0	378.0	217.5	162.0	330.0	75.0	162.0	6.0	0.910	122.5
1140	299.50	28600	2200	50	52.0	200.0	416.0	254.0	184.0	371.5	78.0	184.0	6.0	1.130	180.1
1150	416.78	39800	2000	50	52.0	215.0	476.5	269.2	183.0	372.0	107.0	183.0	6.0	1.950	230.0
1160	585.38	55900	1750	75	77.0	240.0	533.5	304.8	198.0	402.0	114.5	198.0	6.0	2.810	321.1
1170	781.21	74600	1600	75	77.0	280.0	584.0	355.6	216.0	438.0	120.0	216.0	6.0	3.490	448.2
1180	1078.61	103000	1400	75	152.5	300.0	630.0	393.7	239.0	483.5	130.0	239.0	6.0	3.760	591.0
1190	1434.66	137000	1300	85	152.5	335.0	685.0	436.9	260.0	524.5	135.0	259.0	6.0	4.400	761.0
1200	1947.79	186000	1100	85	178.0	360.0	737.0	497.8	279.5	565.0	145.0	279.5	6.0	5.620	1021.0

* Consult RATHI for Max Bore with Square Key.

TAPER GRID COUPLINGS TYPE RGTH

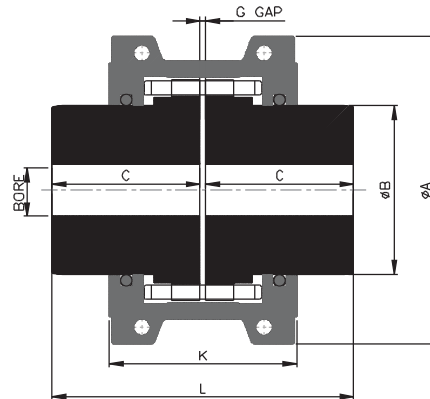

TYPE RGTH

Features

- Torsionally Flexible.
- Vibration dampening - reduced peak / shock loads.
- Accommodates angular, parallel & axial misalignments.
- Low operating cost.
- Smooth & quiet operation.
- Low & easy maintenance.
- Overload conditions cause the grid element to shear, like a mechanical fuse.
- Quick & easy installation.

TECHNICAL DATA

Coupling Size	KW at 100 rpm	Basic Torque (Nm)	Max. Speed (rpm)	PB	Bore Dia (mm)		Dimensions (mm)					G Gap (mm)	Lube weight (Kg)	Coupling Wt. WO Bore (kg)
					Min.	Max.	ϕA	ϕB	C	K	L			
1020	0.54	52	4500	16	18.0	30.0	101.5	39.7	47.5	66.5	98.0	3.0	0.03	1.9
1030	1.56	149	4500	16	18.0	36.0	110.0	49.2	47.5	68.0	98.0	3.0	0.03	2.6
1040	2.61	249	4500	16	18.0	44.0	117.5	57.1	51.0	70.0	104.5	3.0	0.05	3.4
1050	4.56	435	4500	16	18.0	51.0	138.0	66.7	60.0	79.5	123.5	3.0	0.05	5.4
1060	7.16	684	4350	16	18.0	57.0	150.5	76.2	63.5	92.0	130.0	3.0	0.09	7.3
1070	10.41	994	4125	16	18.0	68.0	162.0	87.3	76.0	95.0	155.5	3.0	0.11	10.0
1080	21.47	2050	3600	25	27.0	82.0	194.0	104.8	89.0	116.0	181.0	3.0	0.17	18.0
1090	39.06	3730	3600	25	27.0	95.0	213.0	123.8	98.5	122.0	200.0	3.0	0.25	25.0
1100	65.76	6280	2400	38	40.0	110.0	250.0	142.0	120.5	155.5	245.5	4.5	0.43	42.0
1110	97.60	9320	2250	38	40.0	120.0	270.0	160.3	127.0	161.5	258.5	4.5	0.51	54.0
1120	143.47	13700	2025	50	52.0	140.0	308.0	179.4	149.5	191.5	304.5	6.0	0.73	81.0
1130	208.39	19900	1800	50	52.0	170.0	346.0	217.5	162.0	195.0	330.0	6.0	0.91	121.0
1140	299.50	28600	1650	50	52.0	200.0	384.0	254.0	184.0	201.0	371.5	6.0	1.13	178.0
1150	416.78	39800	1500	50	52.0	215.0	453.0	269.2	183.0	271.0	372.0	6.0	1.95	234.0
1160	585.38	55900	1350	75	77.0	240.0	501.5	304.8	198.0	279.0	402.0	6.0	2.81	317.0
1170	781.21	74600	1225	75	77.0	280.0	566.5	355.6	216.0	304.0	438.0	6.0	3.49	448.0
1180	1078.61	103000	1100	75	152.5	300.0	630.0	393.7	239.0	321.0	483.5	6.0	3.76	619.0
1190	1434.66	137000	1050	85	152.5	335.0	675.5	436.9	259.0	325.0	524.5	6.0	4.40	776.0
1200	1947.79	186000	900	85	179.0	360.0	757.0	497.8	279.5	355.5	565.0	6.0	5.62	1058.0
1210	2607.52	249000	820	85	178.0	390.0	844.5	533.4	305.0	432.0	622.5	12.7	10.50	1424.0
1220	3518.58	336000	730	85	203.0	420.0	920.5	571.5	325.1	490.0	663.0	12.7	16.10	1785.0

* Consult RATHI for Max Bore with Square Key.

Lubrication:

For quality lubrication to get good performance and long life, Rathi Special Grease (RSG) is highly recommended.